



CONSISTENTLY DELIVERING THE HIGHEST QUALITY

PROUDLY SUPPORTING THE
ADVANCEMENT OF NIGERIA'S
INFRASTRUCTURE.

 +234 703 530 1776

 +234 703 784 7461

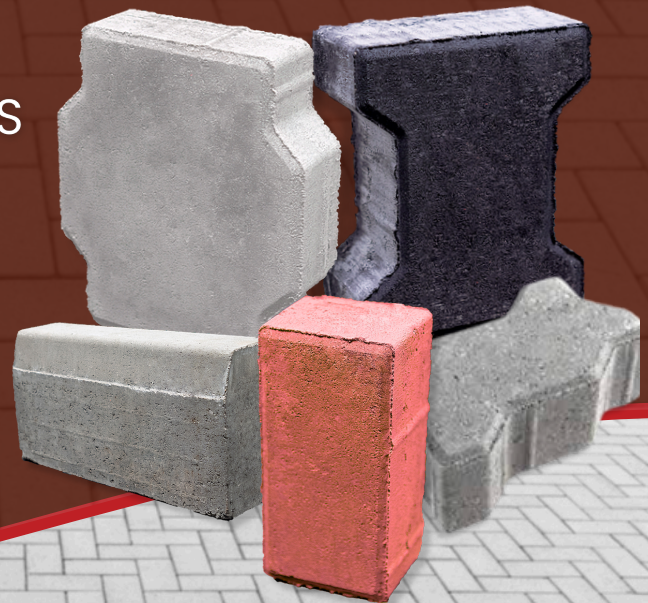

 WWW.HFPPAVINSTONES.COM

 INFO@HFPPAVINSTONES.COM

 Km 58, Lekki-Epe Expressway, Ibeju-Lekki, Lekki, Lagos, Nigeria



ENQUIRE HERE

- **WIDE RANGE OF PRODUCTS**
Specifications to meet any projects requirements | Special requests welcome
- **HIGH CAPACITY PRODUCTION**
No delays | On-demand delivery | Supply for projects of any size
- **FULLY EQUIPPED LABORATORY**
Continuous testing guarantees the highest quality products
- **WORLD CLASS AUTOMATED MACHINERY**
All products are produced to the highest international standards



PRODUCT RANGE

I-TYPE STONES

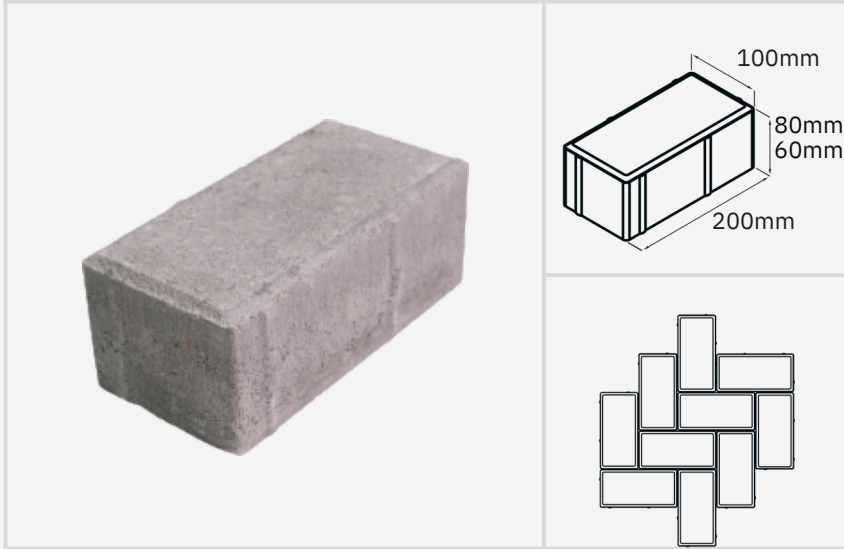

DIMENSIONS
L200 x W100 x H80/H60

UNIT/SQUARE METER
50 pcs

AREA COVERED/PALLET
80mm: 10.8m² | 60mm: 12.96m²

COLOURS



BONE TYPE STONES

DIMENSIONS
L200 x W163 x H80/H60

UNIT/SQUARE METER
36 pcs

AREA COVERED/PALLET
80mm: 9.94m² | 60mm: 11.92m²

COLOURS

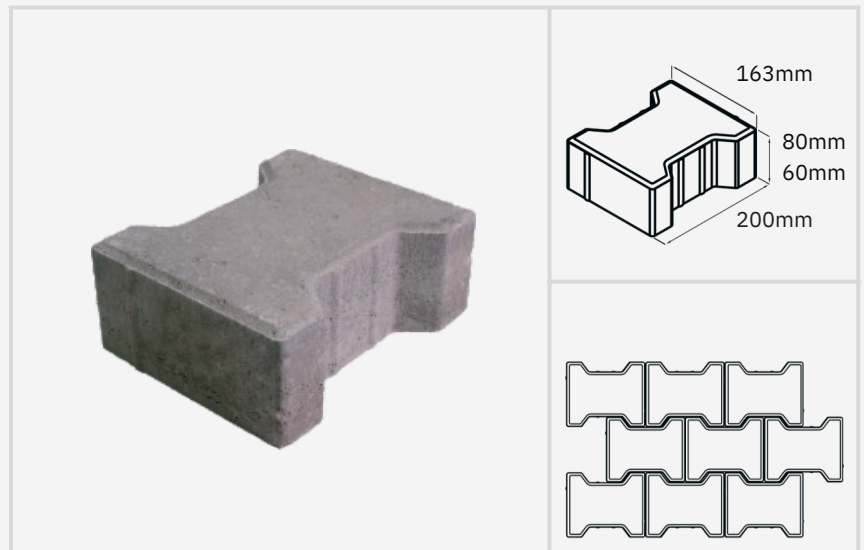
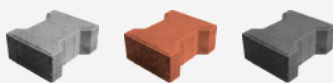

PRODUCT RANGE

BULMAP STONES



DIMENSIONS

L229 x W141 x H80

UNIT/SQUARE METER

39pcs

AREA COVERED/PALLET

10.16m²

COLOURS

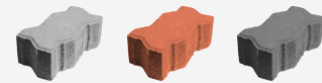

CREST STONES

DIMENSIONS

L253 x W217 x H60

UNIT/SQUARE METER

21pcs

AREA COVERED/PALLET

9.22m²

COLOURS

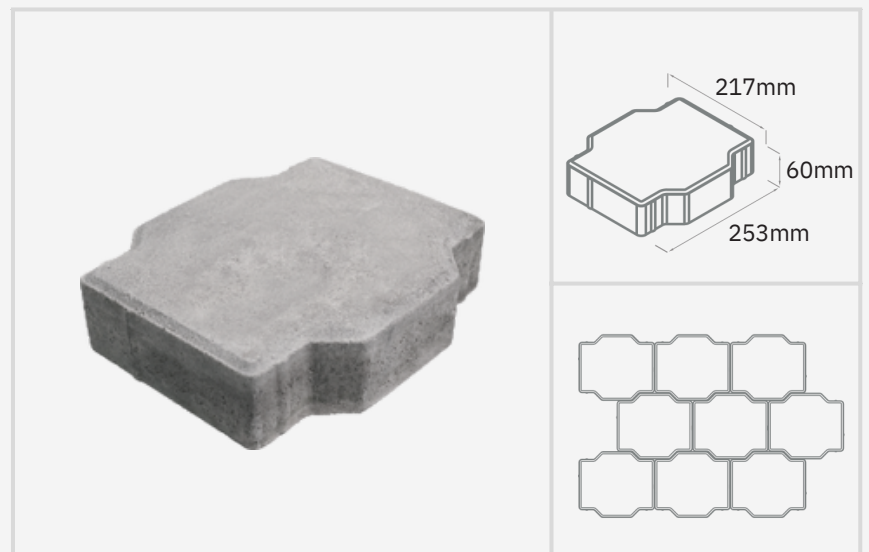
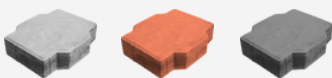

PRODUCT RANGE

ROAD KERB

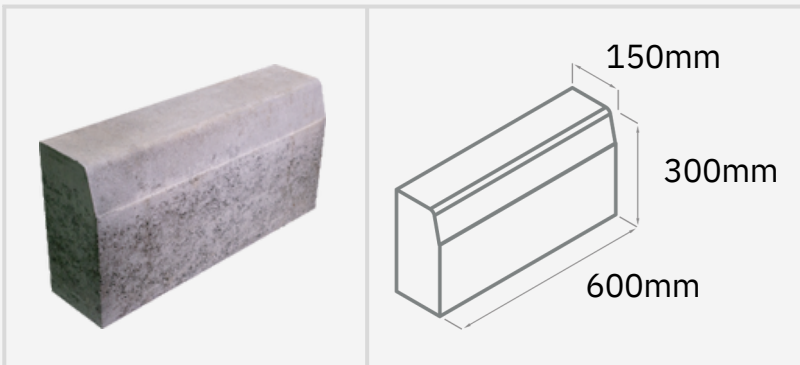

DIMENSIONS
L600 x W150 x H300

UNIT/LINEAR METER
2pcs

APPLICATION
Expressway + Public Roads

GARDEN KERB

DIMENSIONS
L480 x W58 x H250

UNIT/LINEAR METER
2pcs

AREA COVERED/PALLET
Residential + Gardens



DECOR RANGE

DIAMOND TYPE

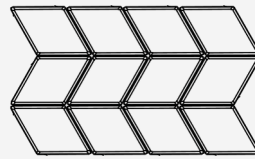
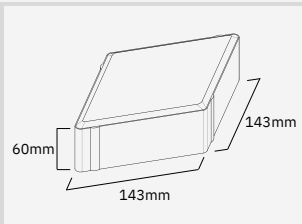

DIMENSIONS

L143 x W143 x H60

UNIT/SQUARE METER

53pcs

COLOURS



V-TYPE

DIMENSIONS

L190 x W190 x H60

UNIT/SQUARE METER

41pcs

COLOURS

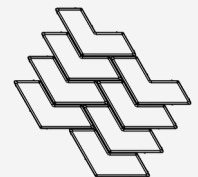
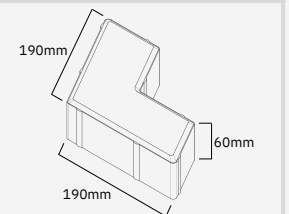

HEX TYPE

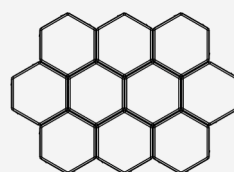
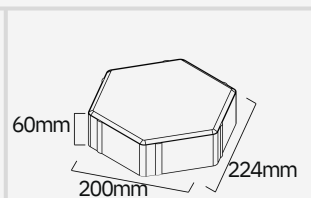

DIMENSIONS

L143 x W143 x H60

UNIT/SQUARE METER

53pcs

COLOURS



WWW.HFPPAVINSTONES.COM



INFO@HFPPAVINSTONES.COM

DECOR RANGE

MULTI BRICKS

		<p>DIMENSIONS L: L248 x W186x H60 M: L124x W186x H60 S: L124x W124 x H60</p> <p>UNIT/SQUARE METER S M L: 67/45/23</p> <p>SURFACE FINISH Natural Stone</p> <p>COLOURS</p>

DECOR SLABS

<p>DIMENSIONS L/S: L600/400 x W200 x H60</p> <p>UNIT/SQUARE METER L/S: 9 / 13 pcs</p> <p>SURFACE FINISH Wood Grain</p> <p>COLOURS</p>		
---	--	--



WE OPERATE TO THE HIGHEST INTERNATIONAL STANDARDS

ABOUT US

HFP Paving stones was established in 2009 with the aim of supporting the growth of Nigeria's core infrastructure. The company has since grown to employ over 220 people, including foremost experts in the field, producing millions of square meters of products each year.

In 2021, HFP Paving Stones installed a second world-class automated manufacturing facility to fulfill customer demand while keeping quality and durability at the forefront of what we do.

